

PinPoint™ Partial Discharge (PD) Monitor

Recognize. Repair. Re-energize!

On-Line Condition Monitoring of Switchgear & Bus Duct Equipment

Increase your equipment life and availability, and avoid potentially catastrophic faults by installing PinPoint in your new or existing equipment. PinPoint will help you shift towards predictive maintenance and improve your asset availability by continually monitoring for partial discharge activity within your Medium Voltage Switchgear, MCC or Bus Duct.

The PinPoint system features a non-contact detection method that uses compact antennas to measure the partial discharge levels in your equipment. Powell's PicoView™ software uses the PinPoint system to determine the location of the PD source within the equipment, allowing you to take proactive and appropriate action.

Operational Benefits

PinPoint monitors the health of your equipment's insulation system, detecting both partial discharge and its location and provides continuous PD surveillance. This system benefits personnel safety, as well as the electrical asset, against potential damage.

- PD detection & location
- Continuous PD surveillance
- Increases equipment life & availability
- Can help avoid potentially catastrophic faults
 - Increasing personnel safety
 - Protecting electrical asset from damage

Why Powell's Solution

- Non-contact PD detectors provide no risk to your insulation system
- Applicable to Medium Voltage Switchgear, MCC and Bus Duct
- Locates the actual source of partial discharge
- Provides 24/7 monitoring
- Competitively priced
- Has a user friendly interface, you won't need expert guidance to interpret the data

PinPoint continuously monitors the health of your medium voltage equipment insulation system. If degradation begins to occur, the location and severity of the problem are identified allowing you to take appropriate actions to prevent further degradation. PinPoint provides a means of avoiding potentially catastrophic incidents to your personnel and electrical assets.

Protect your personnel & assets

Increase equipment life and availability

Monitoring of insulation performance:

- Using PD detection
- 24/7 monitoring
- PD source localization



PinPoint Sentry Control Unit



PinPoint Antenna

Typical Partial Discharge (PD) Monitoring System Installations

Typical Install: Medium Voltage Switchgear

- PinPoint™ antennas are installed into each electrical compartment.
- Antennas receive PD RF emissions.
- PinPoint cards within Sentry® chassis record RF signals for an integration period to watch for presence of PD.
- Analysis computer controls PD data acquisition and sends data to Powell Cloud* for analysis.
- Powell Cloud analyzes PD detected by all Sentry units on network and reports PD events and trends to registered users.
- Powell Cloud identifies compartment and phase where PD is located.

Option exists to host the Powell Cloud as On-Premise service

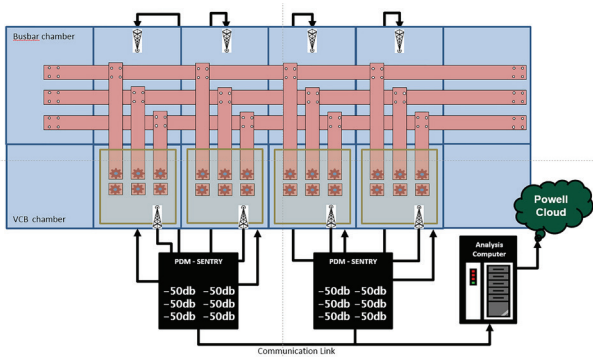

Typical Install: Bus Duct

- PinPoint antennas are installed as pairs along length of the Bus Duct.
- Antennas receive PD RF emissions.
- PinPoint cards within Sentry chassis record RF signals for an integration period watching for presence of PD.
- PinPoint cards measure time-of-arrival difference between antennas for each PD.
- Analysis computer controls PD data acquisition and sends data to Powell Cloud* for analysis.
- Powell Cloud analyzes PD detected by all Sentry units on network and reports PD events and trends and location to registered users.
- Powell Cloud identifies PD location to +/- 1 foot.

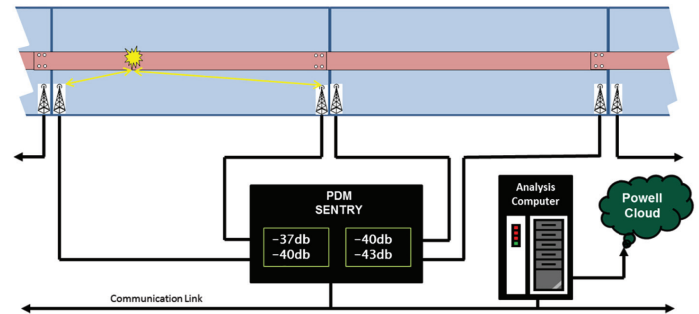

Sentry® Specifications

Rated Voltage:	120-250 VAC/DC 50/60 Hz
Operating Temperature:	-20°C to +70°C
Sentry unit size	6.5"H x 5"W x 4.5"D
Sentry Communication	RS485 - Modbus RTU
UL/CSA Listed	TBC

PinPoint™ Antenna Specifications

Max Switchgear System Voltage:	38 kV (150 kV Impulse)
Operating Temperature:	-20°C to +70°C
Antenna size	2.5"H x 5.7"W x 2.5"D
Antenna connection to Pinpoint	SMA connector to RG223 Coax
Self-test emissions	Max 138 mW for 10 secs

PinPoint™ System Specifications

Applicable Switchgear Voltages	4160 VAC – 38k VAC
PD detection threshold	-34 dBm (~100pC)
Phase reference input level	63.5 VAC – 250 VAC

EMC/Environmental Specification

Ambient Humidity	5-93 %RH
Storage temperatures	-40°C to +90°C
Shock & Vibration:	IEC 60255-21-1,2,3
EMC Compliance	IEEE C37.90.1,2 EN 60255-26:2013 EN 61000-4-2,3,4,5,6,8,9,11,13,16,18 EN 55011
Harsh Environment	EN 60068-2-60 method 4

Powered by Safety®

Asia Pacific
+65 6737 2959

Middle East
+971 4 817 0215

North & South America
1 800 480 7273

UK & Europe
+44 1274 734221

Connect with us!
powellind.com
info@powellind.com